

# 63Z-Meter

Truck-Mounted Concrete Boom Pump



63Z-Meter

- 203' 9" (62.10m) vertical reach
- 5-section Z-Fold boom design
- Twin-wall delivery line on all boom sections
- Up to 260 yd<sup>3</sup>/hr (200m<sup>3</sup>/hr) maximum output
- One-Sided Support (OSS) system

# Putzmeister

FREE FLOW HYDRAULICS

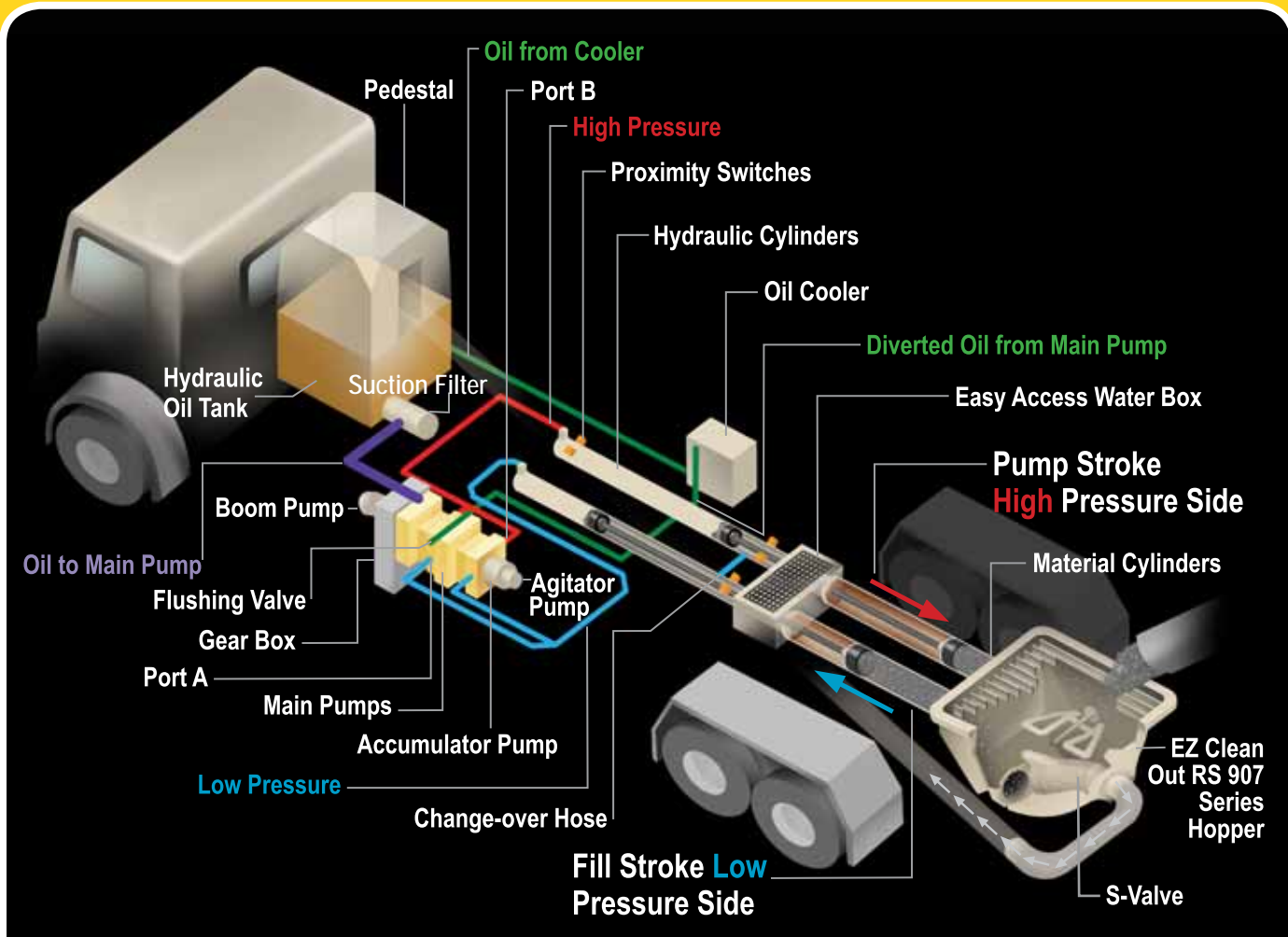

## Putzmeister Free Flow Hydraulics in a Closed Loop System

The pumps at the heart of Putzmeister's free flow pumping system are bi-directional, variable displacement piston pumps. Depending on stroke, oil flows in a closed loop from either port A or port B on the pump to the hydraulic cylinders.

Depending on specific pump cell size, up to 20% of the oil leaves the simple closed loop system during each stroke through a flushing valve on the main pump and cycles to a cooler before it returns to the hydraulic oil tank. Removing and cooling only this minimal amount of oil is possible because, unlike an open loop system, the oil flows freely without passing through any unnecessary valves that can generate heat.

The closed loop also requires far less oil to run the system, as a larger reservoir is not necessary to cool all of the oil.

Speed and timing are also critical to superior performance. Quicker and more responsive than a hydraulic signal, the electrical system on a Putzmeister pump minimizes the time it takes to change direction at stroke end.

An electrical signal precisely synchronizes the drive cylinders with the accumulator system that controls the S-Valve in the hopper. Reserved energy stored in a nitrogen bladder is sent as a supercharged blast of oil at precisely the right moment to facilitate a smooth and fast shift of the S-Valve from one position to another.

## Key Advantages of Putzmeister's Free Flow Hydraulics:

- Changes in material pressure in the delivery line are reduced to ensure smooth pumping and a consistent concrete flow.
- There is greater pump output due to the efficient use of all available energy.
- The intelligent design eliminates wear-inducing pressure peaks, increases service life and makes our pumps extremely powerful.
- Rapid changeover of the stroke means higher outputs, a smoother flow of concrete and less boom bounce.

# Putzmeister

## BOOM PUMP

# ADVANTAGE

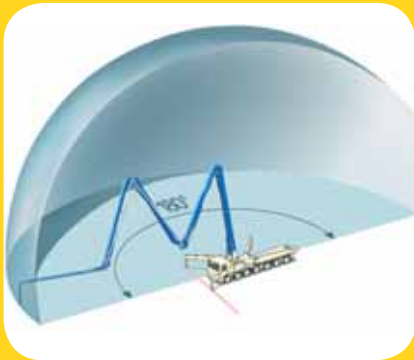

8

### One-Sided Support (OSS) System

For enhanced job site versatility, Putzmeister's unique OSS system allows the operator to reduce the outrigger extension on one side of the unit to create a smaller overall machine footprint. Utilizing a series of sensors, OSS enables the unit to maintain a defined and safe 180 degree working envelope on space restrictive sites that demand a larger boom.



9

### Better Boom Design

Lighter and more resilient, Putzmeister's "smart design" boom incorporates welding seams below the edge of maximum stress. The boom is engineered to offer the flexibility to adapt to different loads, features more straight pipe for a less stressful concrete flow and longer wear on parts. The Z-Fold configuration handles space restrictive areas and can pump even if the boom is not fully extended.



10

### RS 907L Hopper

Putzmeister's EZ Clean Out RS 907L hopper combines an impact resistant solid polyurethane component with a steel base for a durable, yet lightweight design. Engineered for performance and easy maintenance, the RS 907L features quick access to the S-Valve and shift cylinders. Hard-faced remixer paddles and a vibrator complement the hopper's large 19.4 cu. ft. (550L) capacity.

# 63Z-Meter

## Truck-Mounted Concrete Boom Pump Standard

### Boom

- 203' 9" (62.10m) vertical reach
- Versatile 5-section Z-Fold boom
- Automatic lubrication
- Integrated work lights

### Delivery Line

- Equipped with twin-wall delivery line on all boom sections providing efficient concrete delivery
- Induction-hardened deck pipe with Esser turret elbow
- Easy lift-out brackets for simple delivery line replacement

### Pedestal

- Rotation bearing and access openings simplify turret pipe changes
- Fully integrated pedestal design absorbs all forces
- Easy access large single-suction filter with indicator gauge
- Condensation trap in the tank for water collection
- Two spacious decks for convenient pipe and hose storage
- Automatic lubrication
- Side-mounted aluminum toolboxes
- Integrated work lights

### Boom Operation and Control

- Fully proportional HBC radio remote
- Smooth and precise boom positioning greater distances
- Fully proportional cable remote with 164' (50m) cable
- Gauge Port Central (GPC)
- Modular Boom Controls (MBC)
- Ergonic® Boom Control (EBC) with OneTouch™
- 24V electrical system

### Outriggers

- Quick setup on restrictive job sites
- Fully hydraulic outriggers with integral cylinders
- Front outriggers swing out, telescope and extend down
- Rear outriggers swing out and extend down
- Auxiliary fuel tank in outrigger
- Water tank in outrigger
- Four outrigger pads in two side compartments
- One-Sided Support (OSS) system featuring a 180° working range
- Bubble level indicators



## Driven for Performance

Standard on the seven-axle Mack chassis 63Z-Meter model, Putzmeister's unique Low Speed Steer Assist (LSSA) rear steering system increases maneuverability and driver safety while reducing maintenance and wear.

# Features

## EZ Clean Out RS 907L Hopper

- Large 19.4 cu ft (550L) capacity
- Hard-faced remixer paddles
- Vibrator
- Hinged splash guard covers hopper during transit
- Low hopper height allows easy discharge from a mixer truck
- Automatic lubrication
- Integrated work lights

## Clean Out

- Fast and easy clean out
- 406 psi (28 bar) hydraulically-driven water pump
- Wash out kit and hose
- 264 gallon (1000L) water tank in outrigger

## S-Valve

- Ideal for high pressure applications and harsh mixes
- Hard-faced S-Valve
- Gradual 9" to 7" (230 to 180mm) reduction
- Thick-walled valve construction
- Lasting wear over years of use

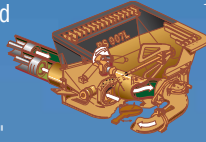

12

## Concrete Pump

- Choose from high pressure or high volume with the same setup
- Free flow hydraulic system for smooth, controllable pumping
- Multi-piece piston cup design
- Automatic lubrication of the concrete pistons for long service life
- Hard-chromed material cylinders
- Fully adjustable volume control for very slow pumping with full concrete pressure and boom speed
- Modular pump control box
- Ergonomic Pump System (EPS)

13



The first of its kind in the concrete pumping industry, LSSA includes three steering axles in the front and two in the rear which are controlled by a computer system to provide a turning radius of only 58 ft. 6 in.

# Putzmeister BOOM PUMP ADVANTAGE



14

## Modular Flatpack

Fully removable, Putzmeister's modular bolt-on flatpack and hydraulic system combine versatility and servicing convenience. This simple design allows for cost-effective, minimally labor intensive pump cell replacement for upgrades, repairs or as part of a maintenance program.



15

## Fuel Economy

Switch gears and save with Putzmeister's patented Econo-Gear™. The exclusive design allows the Mack chassis engine to run at a lower rpm, achieving less stress on wear parts, lower noise levels and reduced fuel consumption. Econo-Gear makes a significant impact on job site safety and profitability with an estimated 10-15% savings.



16

## Convenience and Control

The Frequency Hopping system on the standard HBC proportional radio remote ensures minimal interference with other frequency transmitters. Radiomatic Power Boost further enhances reception quality with a 50-100% increase in signal power. A fully proportional cable remote is also standard. Unlike other remote control systems, the radio and cable remote systems are completely independent, offering redundancies to ensure complete proportional operation with either the radio or cable remote in the event of a problem.



Modular Control Box



Ergonic® Graphic Display



OneTouch™ Radio Remote



## Putting You in Control of Success

7

While size matters, it's nothing without control. Another standard feature on the 63Z-Meter, Putzmeister's Ergonic® technology goes beyond monitoring performance. It also allows the operator to set parameters that control the boom, the pump and various other functions. Ergonic is a main control system that encompasses various modules. These include the Ergonic Pump Control System (EPS) for the pump and various operational functions, Ergonic Tele Service (ETS) for real-time remote diagnosis of computer fault codes in the field and Ergonic Boom Control (EBC).

EPS includes an Ergonic Graphic Display (EGD), featuring a three-inch square LCD screen which allows the operator to both view functions from the unique modular control box and change selected pump settings such as number of strokes per minute, pressure limits, truck rpm and more. This module also includes Ergonic Output Control (EOC), which automatically controls optimum engine rpm while ensuring the lowest possible fuel consumption, reduced wear and low noise levels.

Providing technology to ensure minimal boom bounce, enhanced safety and easy troubleshooting, the Ergonic system features EBC with OneTouch™. This unique module enables the operator to use a single joystick on the radio remote to automatically move all boom sections and slewing in tandem while keeping the end hose level and the boom within prescribed maximum and minimum heights.

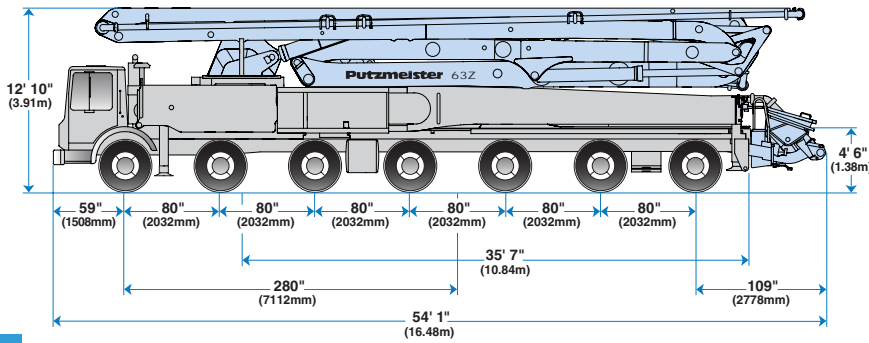

## 63Z-Meter Truck-Mounted Specifications

Based on Model MACK MRU 688S with .16H pump cell

Length	54' 1"	(16.48m)
Width	8' 2"	(2.50m)
Height	12' 10"	(3.91m)
Wheelbase	280"	(7,112mm)
Front axle weight	54,880 lbs	(24,893kg)
Rear axle weight	74,300 lbs	(33,702kg)
Approx. total weight	129,180 lbs	(58,595kg)

Weights are approximate and include pump, boom, truck, full hydraulic oil, driver and some fuel. Varies with options selected.

Dimensions will vary with different truck makes, models and specifications.

## Range Diagram

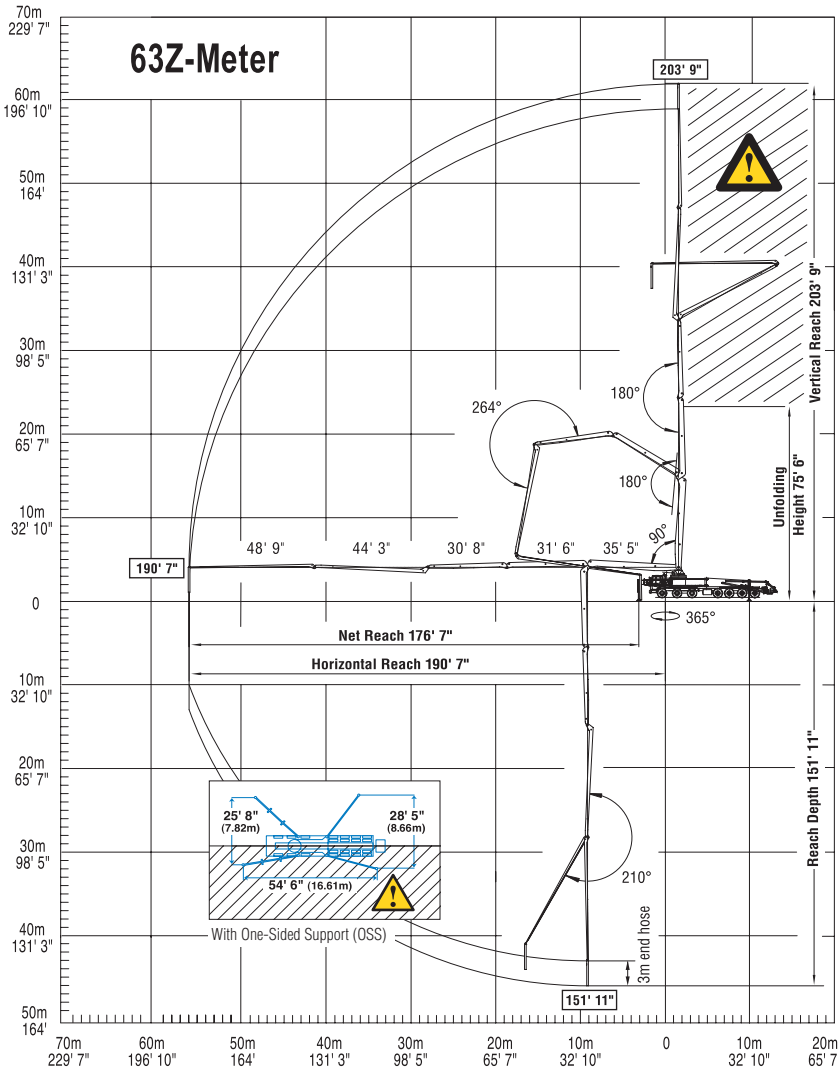

End hose not to be operated in caution area.

Photos and drawings are for illustrative purposes only. For available options, please refer to price list.

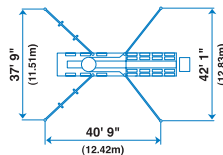

Authorized Distributor

## Boom Specifications • Z-Fold Design

### Height & Reach

Vertical reach	203' 9"	(62.10m)
Horizontal reach	190' 7"	(58.09m)
Reach from front of truck*	176' 7"	(53.82m)
Reach depth	151' 11"	(46.30m)
Unfolding height	75' 6"	(23.01m)

### 5-Section Boom

1st section articulation	90°
2nd section articulation	180°
3rd section articulation	180°
4th section articulation	264°
5th section articulation	210°

1st section length	35' 5"	(10.80m)
2nd section length	31' 6"	(9.60m)
3rd section length	30' 8"	(9.35m)
4th section length	44' 3"	(13.49m)
5th section length	48' 9"	(14.86m)

### General Specs

Pipeline size (ID) metric ends —		
A & B sections	5"	(125mm)
C, D & E sections	4.4"	(112mm)
Rotation	365°	
End hose — length (lightweight)	10'	(3m)
End hose — diameter	4.5"	(115mm)
Outrigger spread L - R — front	37' 9"	(11.51m)
swing out, telescope & extend down		
Outrigger spread L - R — rear	42' 1"	(12.83m)
swing out & extend down		

## Pump Specifications 63Z.16H 63Z.20H

Output — rod side	210 yd <sup>3</sup> /hr (160m <sup>3</sup> /hr)	—
piston side	146 yd <sup>3</sup> /hr (112m <sup>3</sup> /hr)	260 yd <sup>3</sup> /hr (200m <sup>3</sup> /hr)
Pressure — rod side	1233 psi (85 bar)	—
piston side	1885 psi (130 bar) •	1233 psi (85 bar)
Material cylinder diameter	9" (230mm)	11" (280mm)
Stroke length	83" (2100mm)	83" (2100mm)
Max strokes per minute —		
rod side	31	—
piston side	21	26
Volume control	0-Full	0-Full
Vibrator	Standard	Standard
Hard-chromed material cylinders	Standard	Standard
Hydraulic system	Free Flow	Free Flow
Hydraulic system pressure	5075 psi (350 bar)	5075 psi (350 bar)
Differential cylinder diameter	5.5" (140mm)	5.5" (140mm)
Rod diameter	3.1" (80mm)	3.1" (80mm)
Maximum size aggregate	2.5" (63mm)	2.5" (63mm)
Water tank — outrigger	264 gal (1000L)	264 gal (1000L)

Maximum theoretical values listed.

\* Applies to units mounted on PMA stock truck — MACK MRU 688S

• Standard delivery line system rated at max line pressure of 1233 psi (85 bar)



Putzmeister America, Inc.  
1733 90th Street  
Sturtevant, WI 53177 USA  
Telephone (262) 886-3200  
(800) 884-7210  
Facsimile (262) 884-6338  
www.putzmeister.com

