

Putzmeister BOOM PUMP ADVANTAGE



RS 907A Hopper

Putzmeister's EZ Clean Out RS 907A hopper is engineered for performance and easy maintenance. Offering 19.4 cu. ft. (550L) capacity, the hopper features hard-faced remixer paddles and vibrator. The unique design of the impact resistant polyurethane splash guard protects the unit from splattering during pumping and folds down and latches to cover the hopper during transit.



Fuel Economy

Switch gears and save with Putzmeister's patented Econo-Gear.™ The exclusive design allows the Mack chassis engine to run at a lower rpm, achieving less stress on wear parts, lower noise levels and reduced fuel consumption. Econo-Gear makes a significant impact on job site safety and profitability with an estimated 10-15% savings.



Convenience and Control

The Frequency Hopping system on the standard HBC proportional radio remote ensures minimal interference with other frequency transmitters. Radiomatic Power Boost further enhances reception quality with a 50-100% increase in signal power. A fully proportional cable remote is also standard. Unlike other remote control systems, the radio and cable remote systems are completely independent, offering redundancies to ensure complete proportional operation with either the radio or cable remote in the event of a problem.

58-Meter Truck-Mounted Concrete Boom Pump

Putzmeister



- 188' 1" (57.33m) vertical reach
- 4-section roll-and-fold boom design
- 5" (125mm) twin-pipe delivery line
- Up to 260 yd³/hr (200m³/hr) maximum output
- One-Sided Support (OSS) system

58-Meter
58-Meter

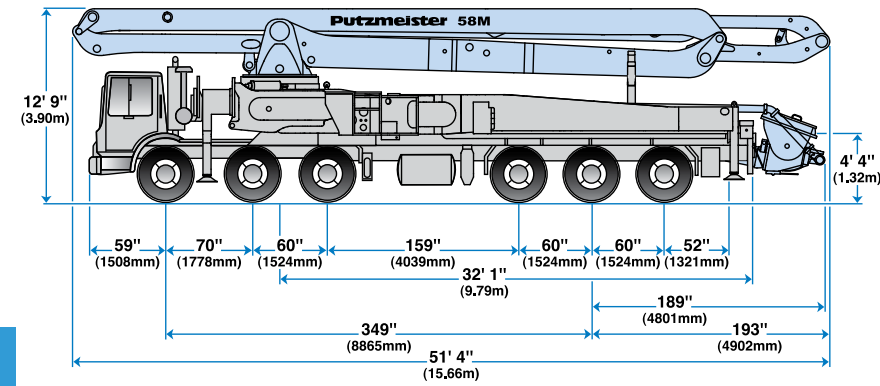

Range Diagram

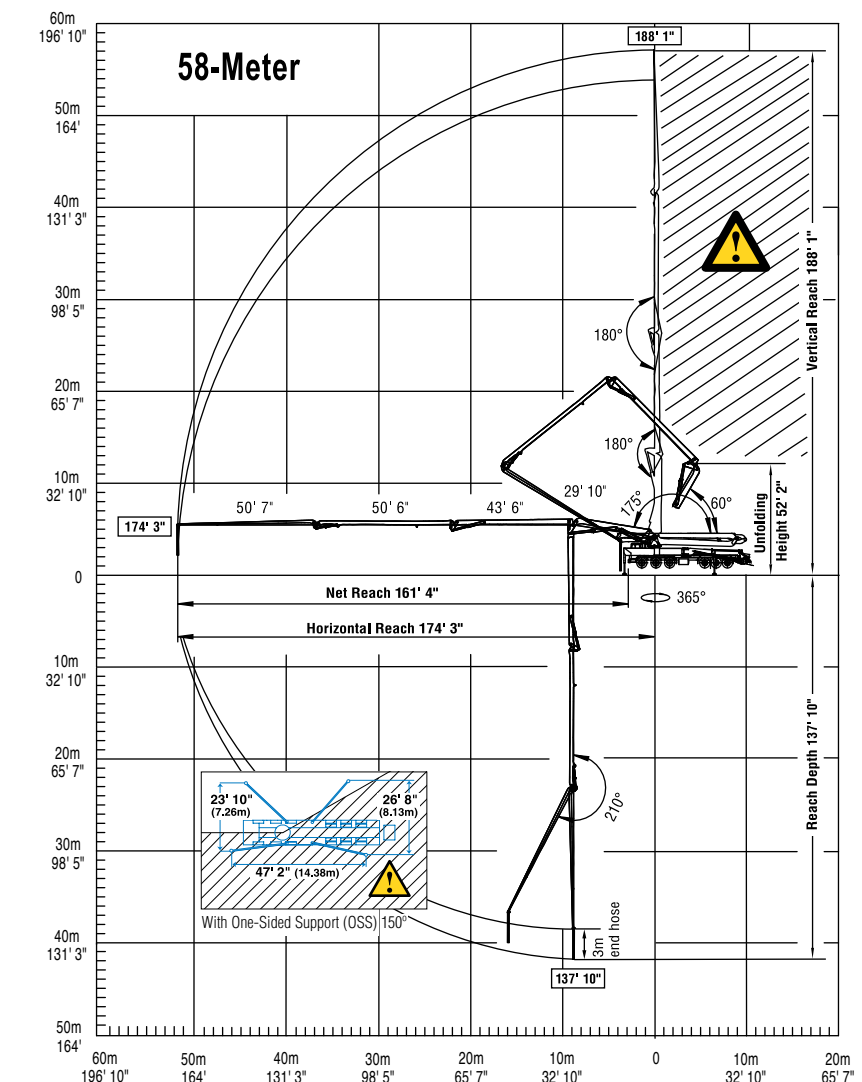

⚠ End hose not to be operated in caution area.

Photos and drawings are for illustrative purposes only. For available options, please refer to price list.

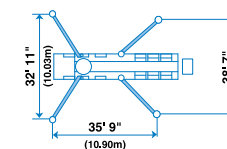

Putzmeister

Putzmeister America, Inc. Telephone (262) 886-3200
1733 90th Street (800) 884-7210
Sturtevant, WI 53177 USA Facsimile (262) 884-6338
www.putzmeister.com



Authorized Distributor

58-Meter Truck-Mounted Specifications

Based on Model MACK MRU 613 with 20H pump cell

Length	51' 4"	(15.66m)
Width	8' 2"	(2.50m)
Height	12' 9"	(3.90m)
Wheelbase	349"	(8,865mm)
Front axle weight	57,560 lbs	(26,109kg)
Rear axle weight	56,200 lbs	(25,492kg)
Approx. total weight	113,760 lbs	(51,601kg)

Weights are approximate and include pump, boom, truck, full hydraulic oil, driver and some fuel. Varies with options selected.

Dimensions will vary with different truck makes, models and specifications.

Boom Specifications • Roll-and-Fold Design

Height & Reach		
Vertical reach	188' 1"	(57.33m)
Horizontal reach	174' 3"	(53.11m)
Reach from front of truck*	161' 4"	(49.17m)
Reach depth	137' 10"	(42.01m)
Unfolding height	52' 2"	(15.90m)

4-Section Boom		
1st section articulation	175°	
2nd section articulation	180°	
3rd section articulation	180°	
4th section articulation	210°	
1st section length	29' 10"	(9.09m)
2nd section length	43' 6"	(13.26m)
3rd section length	50' 6"	(15.39m)
4th section length	50' 7"	(15.42m)

General Specs		
Pipeline size (ID) metric ends	5"	(125mm)
Rotation	365°	
End hose — length	10'	(3.00m)
End hose — diameter	5"	(125mm)
Outrigger spread L - R — front swing out, telescope & extend down	32' 11"	(10.03m)
Outrigger spread L - R — rear swing out & extend down	38' 7"	(11.76m)

Pump Specifications	58Z.16H	58Z.20H
Output — rod side	210 yd ³ /hr (160m ³ /hr)	—
piston side	146 yd ³ /hr (112m ³ /hr)	260 yd ³ /hr (200m ³ /hr)
Pressure — rod side	1233 psi (85 bar)	—
piston side	1885 psi (130 bar)	1233 psi (85 bar)
Material cylinder diameter	9" (230mm)	11" (280mm)
Stroke length	83" (2100mm)	83" (2100mm)
Max strokes per minute — rod side	31	—
piston side	21	26
Volume control	0-Full	0-Full
Vibrator	Standard	Standard
Hard-chromed material cylinders	Standard	Standard
Hydraulic system	Free Flow	Free Flow
Hydraulic system pressure	5075 psi (350 bar)	5075 psi (350 bar)
Differential cylinder diameter	5.5" (140mm)	5.5" (140mm)
Rod diameter	3.1" (80mm)	3.1" (80mm)
Maximum size aggregate	2.5" (63mm)	2.5" (63mm)
Water tank — outrigger	206 gal (780L)	206 gal (780L)

Maximum theoretical values listed.
* Applies to units mounted on PMA stock truck — MACK MRU 613
• Standard delivery line system rated at max line pressure of 1233 psi (85 bar)

Putzmeister BOOM PUMP ADVANTAGE



Extended Range Ergonic[®] Boom Control (EBC)

Helping achieve a greater working range and enhanced maneuverability on the job site, Extended Range EBC significantly expands the capabilities of the 'A' section of this roll-and-fold boom. This increases the working envelope from 120 degrees without the system to a full 170 degrees to access hard-to-reach points of placement.

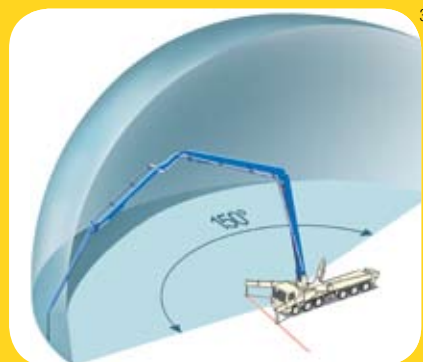

One-Sided Support (OSS) System

For enhanced job site versatility, Putzmeister's unique OSS system allows the operator to reduce the outrigger extension on one side of the unit to create a smaller overall machine footprint. Utilizing a series of sensors, OSS enables the unit to maintain a defined and safe 150 degree working envelope on space restrictive sites that demand a larger boom.



Better Boom Design

Lighter and more resilient, Putzmeister's "smart design" boom incorporates welding seams below the edge of maximum stress. The boom is engineered to offer the flexibility to adapt to different loads and features more straight pipe for a less stressful concrete flow and longer wear on parts.

58-Meter

Truck-Mounted Concrete Boom Pump Standard Features

Boom

- 188' 1" (57.33m) vertical reach
- Versatile 4-section roll-and-fold boom
- Automatic lubrication
- Integrated work lights

Delivery Line

- Equipped with 5" (125mm) twin-pipe delivery line on all boom sections providing efficient concrete delivery
- Esser 900 twin-pipe deck pipe with 900 turret elbow
- Easy lift-out brackets for simple delivery line replacement
- Standardized elbows and straight pipe sections
- Common component availability and easy replacement

Pedestal

- Rotation bearing and access openings simplify turret pipe changes
- Fully integrated pedestal design absorbs all forces
- Easy access large single-suction filter with indicator gauge
- Condensation trap in the hydraulic oil tank for water collection
- Two spacious decks for convenient pipe and hose storage
- Automatic lubrication
- Side-mounted aluminum toolboxes
- Integrated work lights
- Breakaway rear steps

Boom Operation and Control

- Fully proportional HBC radio remote
- Smooth and precise boom positioning at greater distances
- Fully proportional cable remote with 164' (50m) cable
- Gauge Port Central (GPC)
- Modular Boom Controls (MBC)
- Ergonic Boom Control (EBC) with OneTouch™
- Extended Range EBC
- 24V control box
- Operator Supervision Warning System (OSWS)

S-Valve

- Ideal for high pressure applications and harsh mixes
- Hard-faced S-Valve
- Gradual 9" to 7" (230 to 180mm) reduction
- Thick-walled valve construction
- Lasting wear over years of use

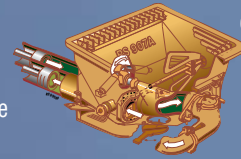

EZ Clean Out RS 907A Hopper

- Large 19.4 cu ft (550L) capacity
- Hard-faced remixer paddles
- Vibrator
- Hinged splash guard covers hopper during transit
- Low hopper height allows easy discharge from a mixer truck
- Automatic lubrication
- Integrated work lights

Concrete Pump

- Choose from high pressure or high volume with the same setup
- Free flow hydraulic system for smooth, controllable pumping
- Multi-piece piston cup design
- Hard-chromed material cylinders
- Redundant proximity sensor system with function indicators
- Fully adjustable volume control for very slow pumping with full concrete pressure and boom speed
- Modular pump control box
- Ergonic Pump System (EPS) with Ergonic Output Control (EOC)

Outriggers

- Quick setup on restrictive job sites
- Fully hydraulic outriggers with integral cylinders
- Front outriggers swing out, telescope and extend down
- Rear outriggers swing out and extend down
- D.O.T. approved auxiliary fuel tank in outrigger
- Water tank in outrigger
- Four outrigger pads in two side compartments
- One-Sided Support (OSS) system featuring a 150° working range
- Bubble level indicators

Clean Out

- Fast and easy clean out
- 406 psi (28 bar) hydraulically-driven water pump
- Wash out kit and hose
- 206 gallon (780L) water tank in outrigger

Putzmeister
PRO-VANTAGE[®]
WARRANTY PLAN

The PRO-VANTAGE[®] Warranty Plan extends the coverage on all Putzmeister BSF boom pumps for a total of 36 months or 6,600 hours at no extra charge.

Ergonic Inside: One System, Multiple Benefits

Housed in an easily accessible single Modular Control Box (MBC), the Ergonic system features microprocessor supported controls that go beyond monitoring performance. They also allow the operator to set parameters that control the boom, the pump and a variety of other operational tasks.

On Putzmeister's large class models like the 58-Meter, this advanced technology includes Ergonic Boom Control (EBC) for controlling the boom; the Ergonic Pump System (EPS) to optimize the pump and other functions; and Ergonic Tele Service (ETS) for remote diagnosis of fault codes.

Putzmeister

FREE FLOW HYDRAULICS

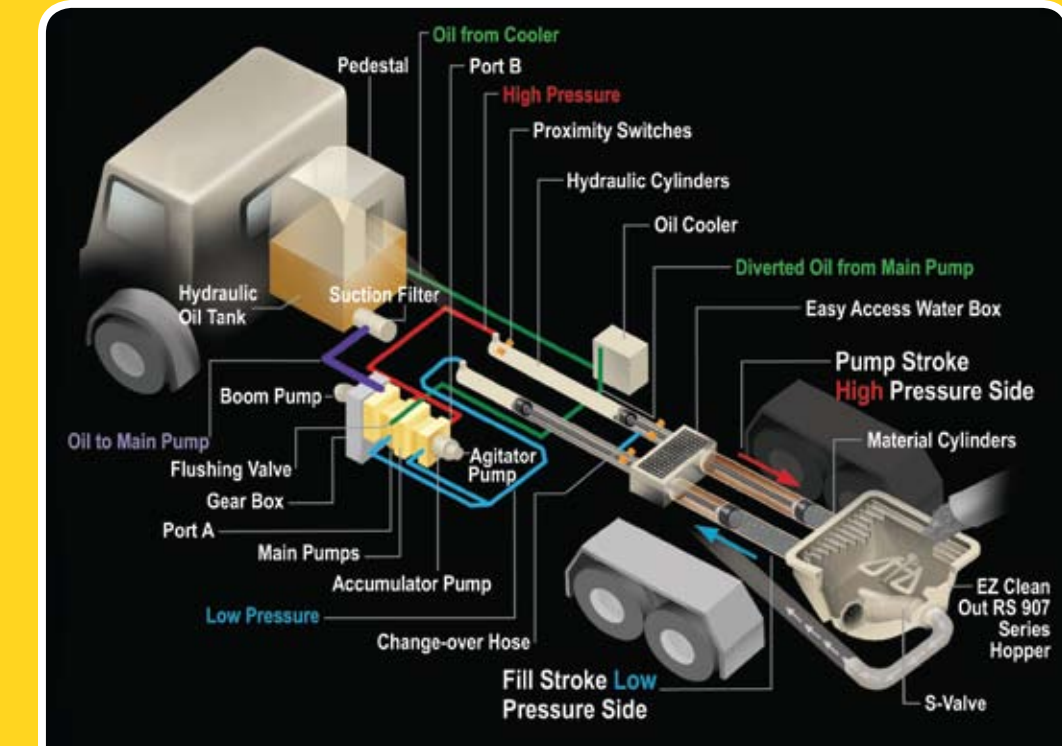

Putzmeister Free Flow Hydraulics in a Closed Loop System

The pumps at the heart of Putzmeister's free flow pumping system are bi-directional, variable displacement piston pumps. Depending on stroke, oil flows in a closed loop from either port A or port B on the pump to the hydraulic cylinders.

Depending on the specific pump cell size, up to 20% of the oil leaves the simple closed loop system during each stroke through a flushing valve on the main pump and cycles to a cooler before it returns to the hydraulic oil tank. Removing and cooling only this minimal amount of oil is possible because, unlike an open loop system, the oil flows freely without passing through any unnecessary valves that can generate heat.

The closed loop also requires far less oil to run the system, as a larger reservoir is not necessary to cool all of the oil.

Speed and timing are also critical to superior performance. Quicker and more responsive than a hydraulic signal, the electrical system on a Putzmeister pump minimizes the time it takes to change direction at stroke end.

An electrical signal precisely synchronizes the drive cylinders with the accumulator system that controls the S-Valve in the hopper. Reserved energy stored in a nitrogen bladder is sent as a supercharged blast of oil at precisely the right moment to facilitate a smooth and fast shift of the S-Valve from one position to another.

Key Advantages of Putzmeister's Free Flow Hydraulics:

- Changes in material pressure in the delivery line are reduced to ensure smooth pumping and a consistent concrete flow.
- There is greater pump output due to the efficient use of all available energy.
- The intelligent design minimizes wear-inducing pressure peaks, increases service life and makes our pumps extremely powerful.
- Rapid change-over of the stroke means higher outputs, a smoother flow of concrete and less boom bounce.